

i-Plate[®]

The Most Innovative Letterplate in the World

Patent Pending Soft Close Mechanism

Available in



304 grade stainless steel finishes

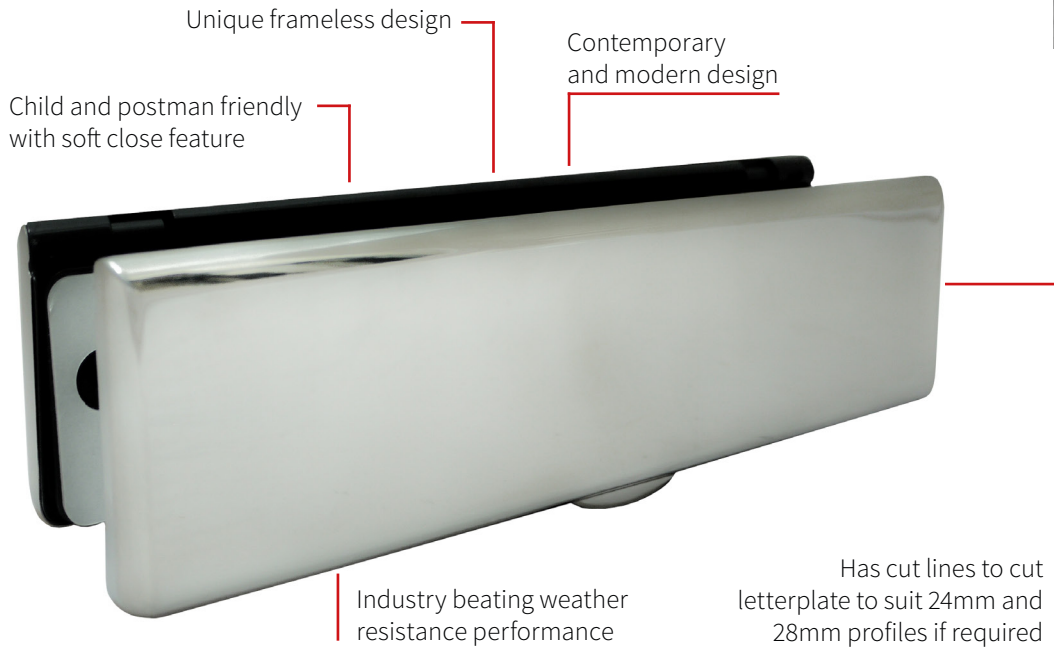

Unique frameless design

Contemporary and modern design

Child and postman friendly with soft close feature

Industry beating weather resistance performance

Has cut lines to cut letterplate to suit 24mm and 28mm profiles if required

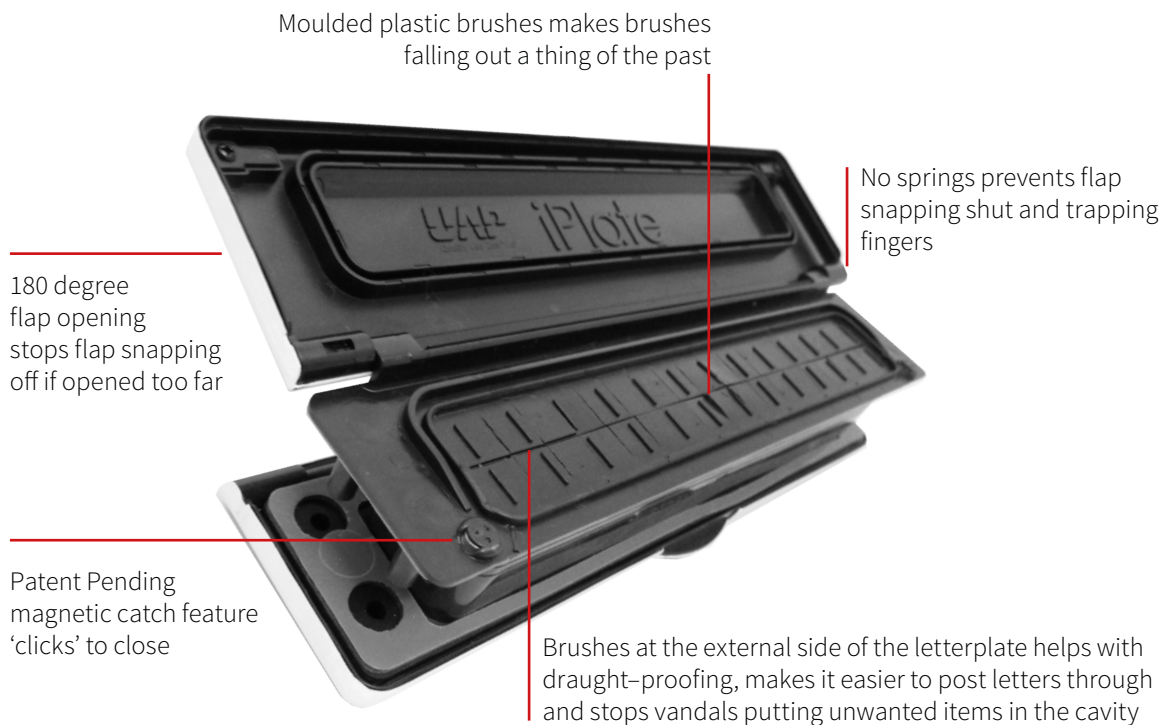

Moulded plastic brushes makes brushes falling out a thing of the past

No springs prevents flap snapping shut and trapping fingers

180 degree flap opening stops flap snapping off if opened too far

Patent Pending magnetic catch feature 'clicks' to close

Brushes at the external side of the letterplate helps with draught-proofing, makes it easier to post letters through and stops vandals putting unwanted items in the cavity

i-Plate[®]

The Most Innovative Letterplate in the World

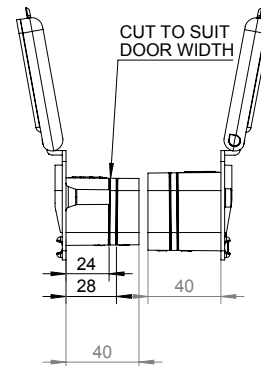
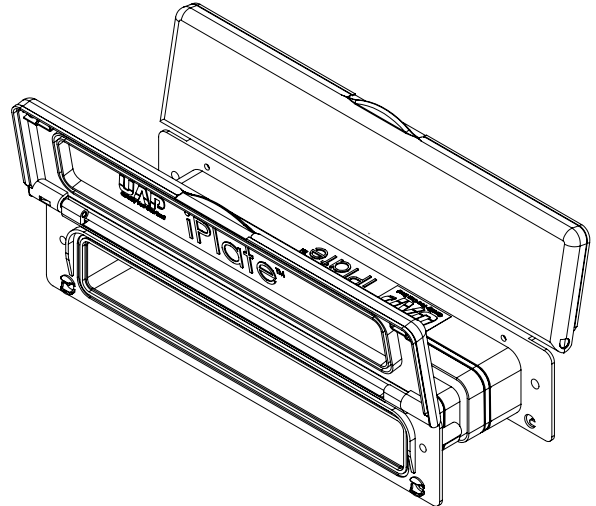
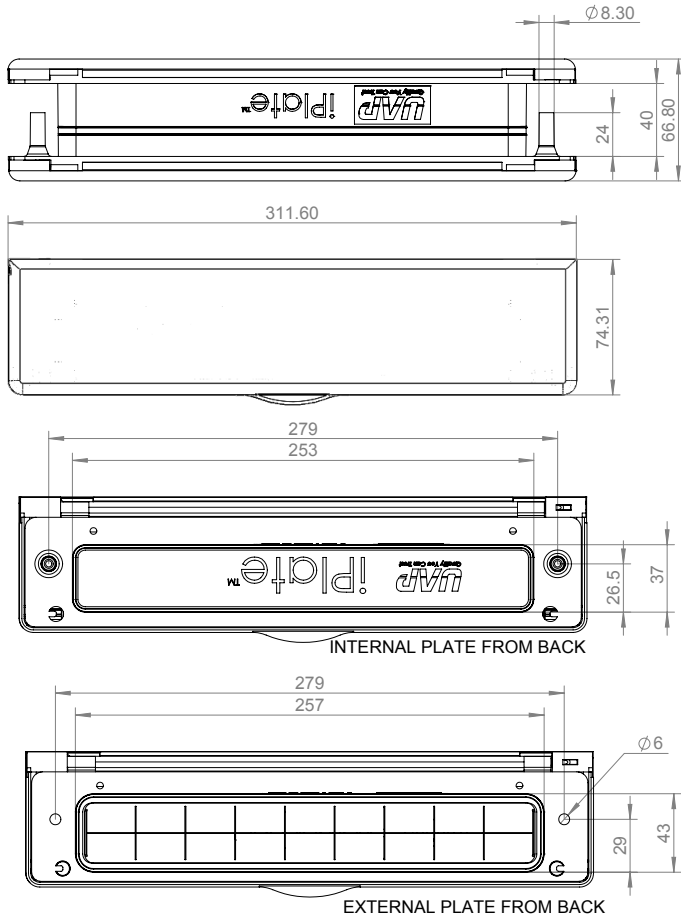

FINISHES:

Gold Anodised
Silver Anodised
Black
White

IPLATEGA
IPLATESA
IPLATEB
IPLATEW



PVD Gold
Mirror Polished
Satin Stainless

IPLATEPVDG
IPLATEMPSS
IPLATESSS

UAP Limited, Unit 1 Albert Close Trading Estate,
Whitefield, Greater Manchester, United Kingdom, M45 8EH
Tel: 0161 796 7268 | Fax: 0161 796 7410 | Email: Sales@uapcorporate.com
www.uapcorporate.com | www.max6mum-security.com

